

# Programmable Automation Controller to manage 6 interpolated axes



## Power J 7" Compact

- display TFT WVGA (800x480) with touch screen
- socket USB
- dimensions 243x146x45 (LxHxP in mm)



## Power J 10" Compact

- display TFT WSVGA (1024x600) with touch screen
- socket USB
- dimensions 310x192x60 (LxHxP in mm)

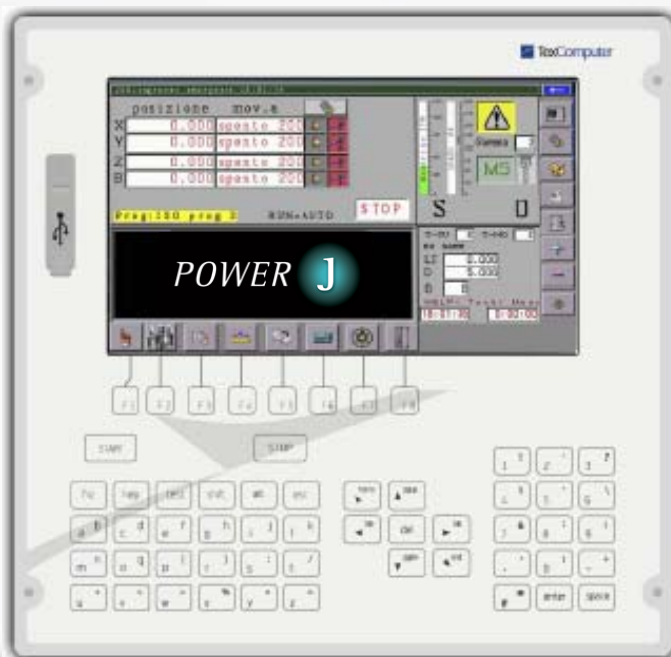

## Power J 10" - 56 keys

- display TFT WSVGA in format 15:9 (1024x600) with touch screen
- 56 key thermoformed membrane keypad
- socket USB
- dimensions 310x300x60 mm

## POWER J Data Sheet ENG

Page 2 of 27

Rel. 1.0.4 - January 11th, 2016



### Fixed remotable terminal

- 10,4" WSVGA 1024x600 display with touch screen, dimensions 310x192x60 (WxHxD in mm)
- connection to Power P Box through 36-pole LVDS cable 10 m. long



### 10.4" Passive mobile terminal

- ergonomic plastic case
- connection to Power E Box through 36-pole LVDS cable, 10 m. long
- TFT WSVGA 1024x600 pixel display with touch screen
- 4-key keypad
- dual-contact mushroom-head emergency button
- optional "dead man" button

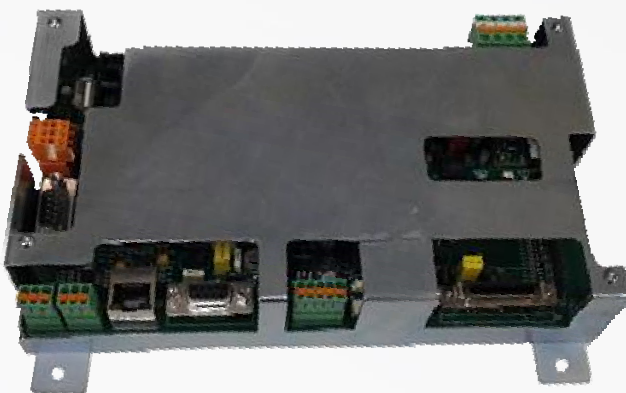

### Power J Box

- control board for wall mounting
- IP00 protection grade
- dimensions 214x157x60 (LxHxP in mm)

Tex Computer Srl  
Sede Legale e Amm.va  
47841 Cattolica (RN)  
Via Mercadante, 35 Italy  
Tel. +39 0541 832 511  
Fax. +39 0541 832 519  
commerciale@texcomputer.com

Tex Computer srl  
Ufficio Olgiate Olona  
21057 Olgiate Olona (VA)  
Corso Sempione, 96 Italy  
Tel +39 0331 643353  
Fax +39 0331 643766  
areanord@texcomputer.com

Tex Computer srl  
Ufficio Tecnico  
48018 FAENZA (RA)  
C.so Mazzini, 116 Italy  
Tel +39 0546 25967  
Fax +39 0546 28094  
ufficiotecnico@texcomputer.com

REA n. 208216  
Cap.Soc. 99.000,00 iv  
Part. IVA 01661960409  
Reg. Imp. di Rimini  
n. 01661960409  
[www.texcomputer.com](http://www.texcomputer.com)



# POWER J Data Sheet ENG

Page 3 of 27

Rel. 1.0.4 - January 11th, 2016

## Technical Data

Description		Notes / Options
CPU	<b>RISC</b>	32 bit, 132 MHz clock
Flash memory (F volume included)	<b>7 MB</b>	
Not volatile Ram (with battery backup)	<b>4 MB</b>	<b>8 MB on request</b>
Calendar clock	<b>Yes</b>	
Touch screen	<b>Yes</b>	
Keyboard management	<b>Yes</b>	Up to 60 keys
Digital inputs 24 Vdc pnp	<b>24</b>	Locally expandable to 40 with INT-SPI
Protected outputs 0.6 Amp. 24Vdc pnp	<b>16</b>	Locally expandable to 32 with INT-SPI
Optoins. outputs 60mA 24Vdc pnp	<b>4</b>	
Analog inputs 0...5 volts - 12 bits	<b>4</b>	3 on terminal board, 1 on P1 connector
Analog inputs 0...5 volts - 12 bits	<b>2</b>	
Analog input +/-10 volts	<b>1</b>	On polarised removable terminal board
Analog input 0-20 mA 12 bit	<b>1</b>	On polarised removable terminal board
Analog inputs 0-10V / 0-20 mA 12 bit	<b>4</b>	On 34 pin P2 connector
Analog outputs +/-10V, from PWM	<b>4</b>	
5V Line Driver encoder interface	<b>4</b>	<b>On request, they can be 5 V Push Pull</b>
STEP / DIRECTION or PWM outputs	<b>for 4 axes</b>	5 V Push Pull signals
RS 232 port / RS485	<b>2</b>	Proprietary protocol, Modbus RTU, <b>on request one can be RS485</b>
CAN port	<b>1</b>	CANopen, CiA 401,402 e 406
Ethernet port 10-100 T	<b>1</b>	TCP/IP, FTP, ModbusTCP and WEB server
Optional fieldbus port	<b>1</b>	<b>CANopen, CiA 401,402 e 406 on INT-CAN2</b>
USB port	<b>1</b>	On front socket with cap or rear
LVDS interface for passive terminal	<b>1</b>	36 pin connector
Power supply	<b>24 Vdc</b>	Energy-saving

Number of axes controllable in PID task in relation to interface type	Type of Feedback used in controller	
	Incremental encoder	None
+/-10V	<b>4</b>	-
PWM	<b>4</b>	-
STEP / DIRECTION	<b>4</b>	<b>4</b>
FIELDBUS (CANopen)	<b>6 total</b>	

Tex Computer Srl  
Sede Legale e Amm.va  
47841 Cattolica (RN)  
Via Mercadante, 35 Italy  
Tel. +39 0541 832 511  
Fax. +39 0541 832 519  
commerciale@texcomputer.com

Tex Computer srl  
Ufficio Olgiate Olona  
21057 Olgiate Olona (VA)  
Corso Sempione, 96 Italy  
Tel +39 0331 643353  
Fax +39 0331 643766  
areanord@texcomputer.com

Tex Computer srl  
Ufficio Tecnico  
48018 FAENZA (RA)  
C.so Mazzini, 116 Italy  
Tel +39 0546 25967  
Fax +39 0546 28094  
ufficiotecnico@texcomputer.com

REA n. 208216  
Cap.Soc. 99.000,00 iv  
Part. IVA 01661960409  
Reg. Imp. di Rimini  
n. 01661960409  
[www.texcomputer.com](http://www.texcomputer.com)



## Warnings

Before powering up the controller you should always check the following:

- 1. That the power is supplied only via terminal M1**
- 2. That the supply voltage never exceeds 27 VDC**
- 3. That the connections between the + and - of the power supplies are not reversed, both incoming or exiting the controller**
- 4. That the encoders are not fed with voltages other than those provided by the controller**
- 5. That the position of connectors having the same number of poles have not been inverted**



Failure to observe any of these recommendations could cause irreparable damage to the controller.

# POWER J Data Sheet ENG

Page 5 of 27

Rel. 1.0.4 - January 11th, 2016

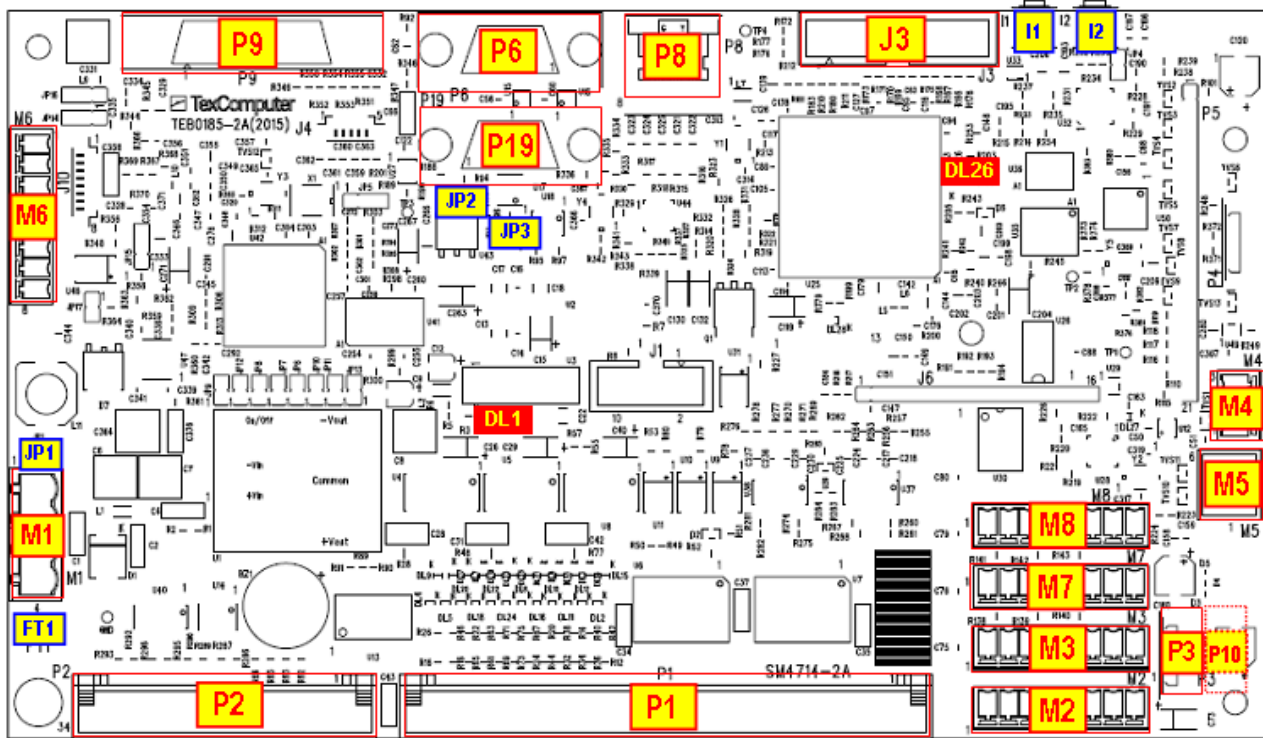

Name	Type	Function
P1	64 pin flat connector	4 Analog outputs +/- 10 V (from PWM # 5, 6, 7 and 8) 1 Emergency input 23 Digital inputs (also for use as Home limit switch) 16 Protected digital outputs PNP 0.6 A – 24 Vdc 4 Opto digital outputs PNP 60 mA – 24 Vdc 1 Analog input 0-5 V (AN27)
P2	34 pin flat connector	PWM / STEP and DIR outputs # 1, 2, 3 and 4 4 Analog inputs 0-10 V / 0-20 mA at 12 bit (AN5/6/7/8) 2 Analog inputs. 0-5 V at 12 bit (AN24/25) 4 3,3V TTL I/O configurable together as input s or outputs
P3	USB connector	Front USB socket
P6	9 pin M D connector	RS232 (COM1 & COM2) – RS485 COM1 optional
P8	RJ45 connector	Ethernet 10/100 T
P9	36 pin D connector	LVDS interface for passive terminal
P10	USB connector	Rear USB connector (weld side) parallel with P3
P19	9 pin F D connector	CAN A (0-63 addressable nodes)
M1	4 pin terminal board	Control power supply
M2	8 pin terminal board	A, B and Z signals, line driver encoder # 1
M3	8 pin terminal board	A, B and Z signals, line driver encoder # 2
M4	3 pin terminal board	Input +/- 10V – 12 bit ADC(32) and 0-20 mA ADC(13)
M5	6 pin terminal board	3 Analog inputs 0-5 Volt at 12 bit ADC(10/11/12)
M6	8 pin terminal board	Power supply and push-buttons on mobile terminal 1 Opto digital output NPN/PNP 60 mA – 24 Vdc
M7	8 pin terminal board	A, B and Z signals, line driver encoder # 3
M8	8 pin terminal board	A, B and Z signals, line driver / push pull encoder # 4
J3	20 pin flat connector	Connection to INT-SPI interface (I/O expansion)

Tex Computer Srl  
Sede Legale e Amm.va  
47841 Cattolica (RN)  
Via Mercadante, 35 Italy  
Tel. +39 0541 832 511  
Fax. +39 0541 832 519  
commerciale@texcomputer.com

Tex Computer srl  
Ufficio Oligiate Olona  
21057 Oligiate Olona (VA)  
Corso Sempione, 96 Italy  
Tel +39 0331 643353  
Fax +39 0331 643766  
areanord@texcomputer.com

Tex Computer srl  
Ufficio Tecnico  
48018 FAENZA (RA)  
C.so Mazzini, 116 Italy  
Tel +39 0546 25967  
Fax +39 0546 28094  
ufficiotecnico@texcomputer.com

REA n. 208216  
Cap.Soc. 99.000,00 iv  
Part. IVA 01661960409  
Reg. Imp. di Rimini  
n. 01661960409  
[www.texcomputer.com](http://www.texcomputer.com)



# POWER J Data Sheet ENG

Page 6 of 27

Rel. 1.0.4 - January 11th, 2016

Name	Type	Function
JP1	Jumper	Short-circuiting of VA power supply with VAX power supply
JP2	Jumper	CAN port termination resistance
JP3	Jumper	Optional RS485 port termination resistance
FT1	Faston connection unit	Ground connection (cable of 2.5 mm <sup>2</sup> )
I1	Microswitch (input i4)	Launch of Boot and Card recovery functions
I2	Microswitch (input i5)	At start up it simulates pression on STOP key
DL1	Red led	Internal power supply OK
DL26	Red led (output o42)	Signalling functions selectable by micro switch I1

**For connectors without numbering, pin 1 is highlighted in red.**

## M1 TERMINAL BOARD (normal power supply)

Terminal	Function
1	VA +24 Vdc power supply
2	GND A 0Vdc DC power supply
3	GND B 0Vdc DC power supply
4	VAX with jumper JP1 closed (default configuration) it's connected to terminal 1

VAX terminal allows you to supply the 0.6A protected outputs independently from the controller's power supply. This is useful especially when the controller's outputs are used on machines which have to respect CE safety regulations.

## M2 TERMINAL BOARD (encoder # 1)

Terminal	Function	Notes
1	CLK A channel A straight encoder # 1	5V Line Driver or Push-Pull*
2	CLK/ A channel A negated encoder # 1	
3	CLK B channel B straight encoder # 1	5V Line Driver or Push-Pull*
4	CLK/B channel B negated encoder # 1	
5	NOTCH /0 channel 0 negated encoder # 1	5V Line Driver or Push-Pull*, readable in interrupt as i56
6	NOTCH 0 channel 0 straight encoder # 1	
7	GND power supply ground encoder # 1	
8	VDC +5Vdc power supply for encoder # 1	

These inputs can be filtered by software acting on Info 1623 and Info 1648.

## M3 TERMINAL BOARD (encoder # 2)

Terminal	Function	Notes
1	CLK A channel A straight encoder # 2	5V Line Driver or Push-Pull*
2	CLK/ A channel A negated encoder # 2	
3	CLK B channel B straight encoder # 2	5V Line Driver or Push-Pull*
4	CLK/B channel B negated encoder # 2	
5	NOTCH /0 channel 0 negated encoder # 2	5V Line Driver or Push-Pull*, readable in interrupt as i57
6	NOTCH 0 channel 0 straight encoder # 2	
7	GND power supply ground encoder # 2	
8	VDC +5Vdc power supply for encoder # 2	

These inputs can be filtered by software acting on Info 1623 and Info 1648.

\* On request, the inputs of encoders can be supplied in 5V Push-Pull configuration; in this case the input signals must be connected to the straight channels and the negated channels must be left disconnected.

Tex Computer Srl  
Sede Legale e Amm.va  
47841 Cattolica (RN)  
Via Mercadante, 35 Italy  
Tel. +39 0541 832 511  
Fax. +39 0541 832 519  
commerciale@texcomputer.com

Tex Computer srl  
Ufficio Olgiate Olona  
21057 Olgiate Olona (VA)  
Corso Sempione, 96 Italy  
Tel +39 0331 643353  
Fax +39 0331 643766  
areanord@texcomputer.com

Tex Computer srl  
Ufficio Tecnico  
48018 FAENZA (RA)  
C.so Mazzini, 116 Italy  
Tel +39 0546 25967  
Fax +39 0546 28094  
ufficiotecnico@texcomputer.com

REA n. 208216  
Cap.Soc. 99.000,00 iv  
Part. IVA 01661960409  
Reg. Imp. di Rimini  
n. 01661960409  
[www.texcomputer.com](http://www.texcomputer.com)



## POWER J Data Sheet ENG

Page 7 of 27

Rel. 1.0.4 - January 11th, 2016

### M4 TERMINAL BOARD (+/- 10V and 0-20 mA input)

Terminal	Function
1	+/- 10 V Analog input readable with ADC(32) operator, range 1640...14744, res..12 bit
2	Analog GND
3	0-20 mA Analog input readable with ADC(13) operator, range 0... 16384, resolut.12 bit

### M5 TERMINAL BOARD (3 analog inputs at 5V)

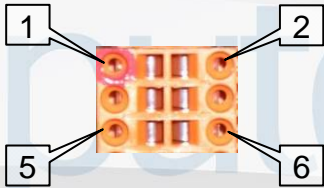
Terminal	Function	Layout
1	Analog GND	
2	5 V Analog input readable with ADC(10) operator	
3	5 V Analog input readable with ADC(11) operator	
4	5 V Analog input readable with ADC(12) operator	
5	Analog GND	
6	+ 5V for potentiometer power supply	

### M6 TERMINAL BOARD (interfacing with mobile terminal)

Terminal	Function
1	EMG NC1 Mushroom-head emergency button contact 1 (N.C.)
2	EMG NC2 Mushroom-head emergency button contact 2 (N.C.)
3	24 VA +24 Vdc (parallel to Pin 1 terminal board M1)
4	EMG COM Mushroom-head emergency button contacts (common)
5	Digital input i7 (parallel to Pin 53 of connector P1)
6	Digital input i22, 24V PNP (parallel to Pin 28 of connector P1); can be connected to the "dead man" button of the mobile terminal
7	Collector of transistor of optoisolator of output o12 (30Vdc – 60 mA)
8	Emitter of transistor of optoisolator of output o12 (30Vdc – 60 mA)

### M7 TERMINAL BOARD (encoder # 3)

Terminal	Function	Notes
1	CLK A channel A straight encoder # 3	5V Line Driver or Push-Pull*
2	CLK/ A channel A negated encoder # 3	
3	CLK B channel B straight encoder # 3	5V Line Driver or Push-Pull*
4	CLK/B channel B negated encoder # 3	
5	NOTCH /0 channel 0 negated encoder # 3	5V Line Driver or Push-Pull*, readable in interrupt as i58
6	NOTCH 0 channel 0 straight encoder # 3	
7	GND power supply ground encoder # 3	
8	VDC +5Vdc power supply for encoder # 3	

These inputs can be filtered by software acting on Info 1623 and Info 1648.

### M8 TERMINAL BOARD (encoder # 4)

Terminal	Function	Notes
1	CLK A channel A straight encoder # 4	5V Line Driver or Push-Pull*
2	CLK/ A channel A negated encoder # 4	
3	CLK B channel B straight encoder # 4	5V Line Driver or Push-Pull*
4	CLK/B channel B negated encoder # 4	
5	NOTCH /0 channel 0 negated encoder # 4	5V Line Driver or Push-Pull*, readable in interrupt as i59
6	NOTCH 0 channel 0 straight encoder # 4	
7	GND power supply ground encoder # 4	
8	VDC +5Vdc power supply for encoder # 4	

Tex Computer Srl  
Sede Legale e Amm.va  
47841 Cattolica (RN)  
Via Mercadante, 35 Italy  
Tel. +39 0541 832 511  
Fax. +39 0541 832 519  
commerciale@texcomputer.com

Tex Computer srl  
Ufficio Olgiate Olona  
21057 Olgiate Olona (VA)  
Corso Sempione, 96 Italy  
Tel +39 0331 643353  
Fax +39 0331 643766  
areanord@texcomputer.com

Tex Computer srl  
Ufficio Tecnico  
48018 FAENZA (RA)  
C.so Mazzini, 116 Italy  
Tel +39 0546 25967  
Fax +39 0546 28094  
ufficiotecnico@texcomputer.com

REA n. 208216  
Cap.Soc. 99.000,00 iv  
Part. IVA 01661960409  
Reg. Imp. di Rimini  
n. 01661960409  
[www.texcomputer.com](http://www.texcomputer.com)



## POWER J Data Sheet ENG

Page 8 of 27

Rel. 1.0.4 - January 11th, 2016

\* On request, the inputs of encoders can be supplied in 5V Push-Pull configuration; in this case the input signals must be connected to the straight channels and the negated channels must be left disconnected.

These inputs can be filtered by software acting on Info 1623 and Info 1648.

### Ethernet Connection

There is one parameter to enable Ethernet connection, one to set its IP address and one to declare its subnet mask; the first and the third one are accessible in the machine parameters, while the Ethernet address is in the "change card parameters" list accessible from the Boot menu (see also "Basic touch screen functions" in this data sheet). If the controller does not have a full hardware keyboard, the Boot menu should be accessed through the touch screen tool bar (remember that this access is protected by a password):

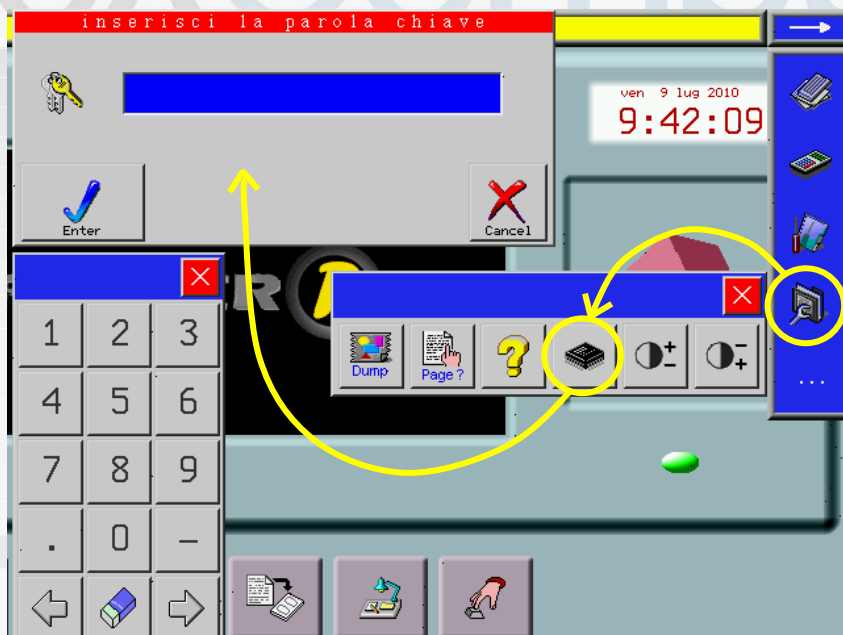

For further information, refer to the "User interface" section of the html manual. By default, the connection is already enabled and the controller can be accessed at IP address 192.168.0.200, subnet mask 255.255.255.0; to make a direct connection to a PLC (peer to peer mode), use a crossover Ethernet cable with 8-pin RJ45 connectors.

### Names of axes

This hardware configuration parameter associates the names of axes to the hardware resources on the motherboard. These resources can be identified per type and differ for a consecutive numbering (e.g. encoder # 1, encoder # 2, PWM # 5 etc.). In the default configuration, the names XYZ are assigned to the axes and the position assumed by each letter indicates the number of the hardware resource which will be associated to the relative axis if installed.

### Installed axes

In order to be installed and rendered operational, the axes must be entered in the specific hardware configuration parameter. The default allocation of the hardware resources can be modified using each axis's respective special parameters.

For example: installing axes X and Y and modifying the "encoder number" parameter of the "X axis special parameters" from the "default" value to value "4" transfers the X axis feedback from encoder # 1 to encoder # 4, while the Y axis feedback will remain the default correlation to # 2.

Tex Computer Srl  
Sede Legale e Amm.va  
47841 Cattolica (RN)  
Via Mercadante, 35 Italy  
Tel. +39 0541 832 511  
Fax. +39 0541 832 519  
commerciale@texcomputer.com

Tex Computer srl  
Ufficio Olgiate Olona  
21057 Olgiate Olona (VA)  
Corso Sempione, 96 Italy  
Tel +39 0331 643353  
Fax +39 0331 643766  
areanord@texcomputer.com

Tex Computer srl  
Ufficio Tecnico  
48018 FAENZA (RA)  
C.so Mazzini, 116 Italy  
Tel +39 0546 25967  
Fax +39 0546 28094  
ufficiotecnico@texcomputer.com

REA n. 208216  
Cap.Soc. 99.000,00 iv  
Part. IVA 01661960409  
Reg. Imp. di Rimini  
n. 01661960409  
[www.texcomputer.com](http://www.texcomputer.com)



## POWER J Data Sheet ENG

Page 9 of 27

Rel. 1.0.4 - January 11th, 2016

The freed resources (encoder # 1 in the example) can be used by other axes or managed through specific commands available in the programming language.

### Parameters to associate hardware resources to the axes

"PWM/DAC/freq output number": destination of the PID output of the axis (valid values from 1 to 16).

"encoder number": velocity/position feedback of the axis (valid values from 1 to 6)

"enabling output": output to enable the drive of the axis (any available user output is valid).

"zero sensor": input to change the position of the axis (only interrupt inputs are valid)

"minimum sensor": input to limit the minimum stroke of the axis (any available input is valid).

"maximum sensor": input to limit the maximum stroke of the axis (any available input is valid). The output which controls the direction of the axis cannot be changed from the default setting.

### Management of the limit switches dedicated to the axes

The inputs with a preset function are associated by default to each axis installed:

- **Zero Limit Switch**, which allows modification of the axis's position at the moment of deactivation or on reception of a pulse generated by the encoder by means of the "0 Notch" signal. The input must be controllable in interrupt mode.
- the **Minimum Limit Switch** which, when activated, halts movement of the axis, switches it to alarm status and prevents any movement towards lower position values. The input must remain active until the physical bottom limit for axis travel is reached.
- the **Maximum Limit Switch** which when activated halts movement of the axis, switches it to alarm status and prevents any movement towards higher position values. The input must remain active until the physical top limit for axis travel is reached.

Generally, the Zero Limit Switch can also simultaneously serve as one of the two other limit switches (minimum or maximum), therefore by default the Zero and Minimum Limit Switches use the same input.

### Interrupt Inputs

All the inputs on the motherboard can be controlled in interrupt mode.

### +/- 10V Analog input

To use correctly analog input connected to pin 1 of terminal M4, you have to execute linearization of the value read through ADC (32) operator, considering that:

- an input value of -10V corresponds to a value of 1640  $\mu\text{m}$
- an input value of 0V corresponds to a value of 8192  $\mu\text{m}$
- an input value of +10V corresponds to a value of 14744  $\mu\text{m}$

As the converter's resolution is 12 bit, the minimum change noticeable will be 1,5996  $\mu\text{m}$

### Other analog inputs

All analog inputs read by the operator ADC (xx) must be linearized with respect to the value of full scale (FS) of the input taking into account that:

- an input value of 0 % FS corresponds to a value of 0  $\mu\text{m}$
- an input value of 100% FS corresponds to a value of 16384  $\mu\text{m}$

As the converter's resolution is 12 bit, the minimum change noticeable will be 4  $\mu\text{m}$

Tex Computer Srl  
Sede Legale e Amm.va  
47841 Cattolica (RN)  
Via Mercadante, 35 Italy  
Tel. +39 0541 832 511  
Fax. +39 0541 832 519  
commerciale@texcomputer.com

Tex Computer srl  
Ufficio Olgiate Olona  
21057 Olgiate Olona (VA)  
Corso Sempione, 96 Italy  
Tel +39 0331 643353  
Fax +39 0331 643766  
areanord@texcomputer.com

Tex Computer srl  
Ufficio Tecnico  
48018 FAENZA (RA)  
C.so Mazzini, 116 Italy  
Tel +39 0546 25967  
Fax +39 0546 28094  
ufficiotecnico@texcomputer.com

REA n. 208216  
Cap.Soc. 99.000,00 iv  
Part. IVA 01661960409  
Reg. Imp. di Rimini  
n. 01661960409  
[www.texcomputer.com](http://www.texcomputer.com)



# POWER J Data Sheet ENG

Page 10 of 27

Rel. 1.0.4 - January 11th, 2016

## P1 CONNECTOR (Analog outputs and digital I/O)

Pin	DESCRIPTION	NOTES
1	GNDANAL X X axis analog ground	
2	VREF X X reference signal, +/- 10V	obtained from PWM channel # 5
3	GNDANAL Y Y axis analog ground	
4	VREF Y Y reference signal, +/- 10V	obtained from PWM channel # 6
5	GNDANAL Z Z axis analog ground	
6	VREF Z Z reference signal, +/- 10V	obtained from PWM channel # 7
7	GNDANAL W W axis analog ground	
8	VREF W W reference signal, +/- 10V	obtained from PWM channel # 8
9	GND logic ground for connection to screen	
10	GND logic ground for connection to screen	
11	User output o0	
12	User input i37	RUNPLC
13	User output o1	
14	User input i38	HOLDCNC
15	User output o2	
16	User input i0	
17	User output o3	
18	User input i1	
19	User output o4	
20	User input i2	
21	User output o5	
22	User input i3	
23	User output o6	
24	User output o10	
25	User output o7	
26	User output o11	
27	User output o8	
28	User input i22	In parallel with pin 6 connector M6 (dead man)
29	User output o9	
30	GNDA I/O power supply ground	
31	User output o16	by default = ENBX enabling of driver # 1 (X) - 24 V PNP - 60 mA powered by VA
32	VA +24 power supply	
33	User output o17	by default = ENBY enabling of driver # 2 (Y) - 24 V PNP - 60 mA powered by VA
34	User input i17	
35	User output o18	by default = ENBZ enabling of driver # 3 (Z) - 24 V PNP - 60 mA powered by VA
36	User input i6	
37	User output o19	by default = ENBW enabling of driver # 4 (W)
38	User input i23	
39	User in i46	by default = Zero limit stop of axis # 4 (W)
40	User in i40	by default = Zero limit stop of axis # 1 (X)
41	FCEMG emergency stop	s127, if EMG is deactivated becomes User in i47
42	User in i41	by default = Max limit stop of axis # 1 (X)
43	User output o32	DIRO X direction output, axis # 1(X)
44	User in i42	by default = Zero limit stop of axis # 2 (Y)
45	User output o33	DIRO Y direction output, axis # 2(Y)
46	User in i43	by default = Max limit stop of axis # 2 (Y)
47	User output o34	DIRO Z direction output, axis #3 (Z)

Tex Computer Srl  
Sede Legale e Amm.va  
47841 Cattolica (RN)  
Via Mercadante, 35 Italy  
Tel. +39 0541 832 511  
Fax. +39 0541 832 519  
commerciale@texcomputer.com

Tex Computer srl  
Ufficio Olgiate Olona  
21057 Olgiate Olona (VA)  
Corso Sempione, 96 Italy  
Tel +39 0331 643353  
Fax +39 0331 643766  
areanord@texcomputer.com

Tex Computer srl  
Ufficio Tecnico  
48018 FAENZA (RA)  
C.so Mazzini, 116 Italy  
Tel +39 0546 25967  
Fax +39 0546 28094  
ufficiotecnico@texcomputer.com

REA n. 208216  
Cap.Soc. 99.000,00 iv  
Part. IVA 01661960409  
Reg. Imp. di Rimini  
n. 01661960409  
[www.texcomputer.com](http://www.texcomputer.com)



## POWER J Data Sheet ENG

Page 11 of 27

Rel. 1.0.4 - January 11th, 2016

Pin	DESCRIPTION	NOTES
48	User in i44	by default = Zero limit stop of axis # 3 (Z)
49	User in i21	
50	User in i45	by default = Max limit stop of axis # 3 (Z)
51	VA +24 power supply	
52	User in i16	
53	User in i7	In parallel with pin 5 connector M6
54	User in i20	
55	GND A I/O power supply ground	
56	GND A I/O power supply ground	
57	User in i18	
58	User in i19	
59	GND A I/O power supply ground	
60	Analog input 27 – assignment to ADC (27)	Non-buffered 0-5V
61	GND A I/O power supply ground	
62	VAX I/O +24 Power supply	
63	User output o40	24 V PNP - 60 mA powered by VA
64	VAX I/O +24 power supply	

The GNDANAL signals must be connected to the differential inputs of the DRIVES (where the inputs are available, of course). If the differential input is not provided, this signal must not be connected.

In this case the GND is used as common reference between POWER J and DRIVE.

In the case of DRIVES without differential input, it might be necessary to connect the screened cable to ground at both ends or to connect the -vref signal of the drive directly to ground in the gnd drive. It depends on the specifications of drive and how the control panel is constructed.

The analog motor control signal is obtained by converting the digital PWM signal into analog with an integrator; the "drive type" parameter must be set at 1 and the PWM resolution can be set at 13 or 14 bit.

**Tex Computer Srl**  
Sede Legale e Amm.va  
47841 Cattolica (RN)  
Via Mercadante, 35 Italy  
Tel. +39 0541 832 511  
Fax. +39 0541 832 519  
commerciale@texcomputer.com

**Tex Computer srl**  
Ufficio Olgiate Olona  
21057 Olgiate Olona (VA)  
Corso Sempione, 96 Italy  
Tel +39 0331 643353  
Fax +39 0331 643766  
areanord@texcomputer.com

**Tex Computer srl**  
Ufficio Tecnico  
48018 FAENZA (RA)  
C.so Mazzini, 116 Italy  
Tel +39 0546 25967  
Fax +39 0546 28094  
ufficiotecnico@texcomputer.com

REA n. 208216  
Cap.Soc. 99.000,00 iv  
Part. IVA 01661960409  
Reg. Imp. di Rimini  
n. 01661960409  
[www.texcomputer.com](http://www.texcomputer.com)



# POWER J Data Sheet ENG

Page 12 of 27

Rel. 1.0.4 - January 11th, 2016

## P2 CONNECTOR (PWM / STEP and DIR # 1, 2, 3 and 4 + analog inputs)

Pin	DESCRIPTION	NOTES
1	VDC +5Vdc power supply for encoder	
2	PWM / STEP # 1 driver control output	Note 1
3	GND logic ground	
4	DIR # 1 driver direction output	User output o24 (5V TTL)
5	GND logic ground	
6	PWM / STEP # 2 driver control output	Note 1
7	GND logic ground	
8	DIR # 2 driver direction output	User output o25 (5V TTL)
9	GND logic ground	
10	PWM / STEP # 3 driver control output	Note 1
11	GND logic ground	
12	DIR # 3 driver direction output	User output o26 (5V TTL)
13	User in i48 / User out o48	Note 3
14	PWM / STEP # 4 driver control output	Note 1
15	User in i49 / User out o49	Note 3
16	DIR # 4 driver direction output	User output o27 (5V TTL)
17	ENABLE # 2 negated (0 = driver enabled)	User output o21 (5V TTL)
18	ENABLE # 1 negated (0 = driver enabled)	User output o20 (5V TTL)
19	ENABLE # 4 negated (0 = driver enabled)	User output o23 (5V TTL)
20	ENABLE # 3 negated (0 = driver enabled)	User output o22 (5V TTL)
21	VREF + 5Vdc reference for analog inputs	
22	AGND analog ground for analog inputs	
23	Analog input 6 – assignment to ADC (6)	Note 2
24	Analog input 5 – assignment to ADC (5)	Note 2
25	Analog input 8 – assignment to ADC (8)	Note 2
26	Analog input 7 – assignment to ADC (7)	Note 2
27	Analog input 24 – assignment to ADC (24)	Non-buffered 0-5V
28	AGND analog ground for analog inputs	
29	Analog input 25 – assignment to ADC (25)	Non-buffered 0-5V
30	AGND analog ground for analog inputs	
31		Reserved for future developments
32	User in i52 / User out o52	Note 3
33		Reserved for future developments
34	User in i53 / User out o53	Note 3

**Note 1:** The PWM signal can become a STEP signal if you set the *drive type* special parameter at value 8; if *other motor parameter* is set at 0 the axis feedback is an encoder, if it is at 1 the pulses generated by the STEP output are used as feedback. The *motor output offset* special parameter should also be set at a value different from 0 to avoid that the stabilization time is too long when the target position is reached. Max. frequency of the STEP signal is 263 KHz if INFO 1154=1 and may fall to 37 KHz if INFO 1154 = 7 (further information in "Power Family.chm" manual).

**Note 2:** Buffered analog inputs with resolution 12 bit: they accept voltages between 0 and 10 volts. Their input resistance towards AGND is 200 Kohm. On request, they can be supplied as current inputs with input resistance 500 ohm.

**Note 3:** 3,3V TTL I/O configurable together with Hardware parameter "I/O direction 48..53" (0 for inputs, 1 for outputs). With INT-185 interface these I/Os can be used only as inputs i48, i49 and i52.

**WARNING:** this document only describes the electrical connections of the connectors most often used. For all further information about the electrical connections and programming of the controller, refer to the manual supplied as a "Compiled HTML Help" file called "Power Family.chm"; this manual is on the CD supplied with the controller and can also be downloaded from the "Download Service" area of the site [www.texcomputer.com](http://www.texcomputer.com).

Tex Computer Srl  
Sede Legale e Amm.va  
47841 Cattolica (RN)  
Via Mercadante, 35 Italy  
Tel. +39 0541 832 511  
Fax. +39 0541 832 519  
commerciale@texcomputer.com

Tex Computer srl  
Ufficio Olgiate Olona  
21057 Olgiate Olona (VA)  
Corso Sempione, 96 Italy  
Tel +39 0331 643353  
Fax +39 0331 643766  
areanord@texcomputer.com

Tex Computer srl  
Ufficio Tecnico  
48018 FAENZA (RA)  
C.so Mazzini, 116 Italy  
Tel +39 0546 25967  
Fax +39 0546 28094  
ufficiotecnico@texcomputer.com

REA n. 208216  
Cap.Soc. 99.000,00 iv  
Part. IVA 01661960409  
Reg. Imp. di Rimini  
n. 01661960409  
[www.texcomputer.com](http://www.texcomputer.com)



**DIGITAL INPUTS (consecutive numbering)**

input	connector	pin	notes
i0	P1	16	
i1	P1	18	
i2	P1	20	
i3	P1	22	
i4	-	-	I1 push button
i5	-	-	I2 push button
i6	P1	36	
i7	P1	53	in parallel with pin 5 connector M6
i16	P1	52	
i17	P1	34	
i18	P1	57	
i19	P1	58	
i20	P1	54	
i21	P1	49	
i22	P1	28	in parallel with pin 6 connector M6
i23	P1	38	
i37	P1	12	RUNPLC (activates the PLC program)
i38	P1	14	HOLDCNC (suspends CNC execution)
i40	P1	40	Axis # 1 (X) zero limit stop
i41	P1	42	Axis # 1 (X) max limit stop
i42	P1	44	Axis # 2 (Y) zero limit stop
i43	P1	46	Axis # 2 (Y) max limit stop
i44	P1	48	Axis # 3 (Z) zero limit stop
i45	P1	50	Axis # 3 (Z) max limit stop
i46	P1	39	Axis # 4 (W) zero limit stop
i47	P1	41	EMERGENCY s127,(if EMG is deactivated it is i47)
i48 *	P2	13	Configurable also as o48 *
i49 *	P2	15	Configurable also as o49 *
i52 *	P2	32	Configurable also as o52 *
i53 *	P2	34	Configurable also as o53 *
i56	M2	5 & 6	Enc. # 1 zero notch, 5V Line Driver, usable in interrupt
i54	-	-	<b>Internal alarm on input modules.</b>
i55	-	-	<b>Internal alarm on output modules:</b> normally at 0, it switches to 1 if one or more outputs go into thermal protection or if the VAX voltage drops below 10.5V.
i57	M3	5 & 6	Enc. # 2 zero notch, 5V Line Driver, usable in interrupt
i58	M7	5 & 6	Enc. # 3 zero notch, 5V Line Driver, usable in interrupt
i59	M8	5 & 6	Enc. # 4 zero notch, 5V Line Driver or 5V Push Pull **, usable in interrupt

## POWER J Data Sheet ENG

Page 14 of 27

Rel. 1.0.4 - January 11th, 2016

\* 3,3V TTL I/O configurable together with Hardware parameter " I/O direction 48...53" (0 for inputs, 1 for outputs). With INT-185 interface these I/Os can be used only as inputs i48, i49 and i52.

\*\* On request, the inputs of encoder # 4 can be supplied in 5V Push-Pull configuration; in this case the input signals must be connected to the straight channels and the negated channels must be left disconnected.



# TexComputer

**Tex Computer Srl**  
**Sede Legale e Amm.va**  
47841 Cattolica (RN)  
Via Mercadante, 35 Italy  
Tel. +39 0541 832 511  
Fax. +39 0541 832 519  
commerciale@texcomputer.com

**Tex Computer srl**  
**Ufficio Olgiate Olona**  
21057 Olgiate Olona (VA)  
Corso Sempione, 96 Italy  
Tel +39 0331 643353  
Fax +39 0331 643766  
areanord@texcomputer.com

**Tex Computer srl**  
**Ufficio Tecnico**  
48018 FAENZA (RA)  
C.so Mazzini, 116 Italy  
Tel +39 0546 25967  
Fax +39 0546 28094  
ufficiotecnico@texcomputer.com

REA n. 208216  
Cap.Soc. 99.000,00 iv  
Part. IVA 01661960409  
Reg. Imp. di Rimini  
n. 01661960409  
[www.texcomputer.com](http://www.texcomputer.com)



# POWER J Data Sheet ENG

Page 15 of 27

Rel. 1.0.4 - January 11th, 2016

## DIGITAL OUTPUTS (consecutive numbering)

output	connector	pin	powered from	notes
o0	P1	11	VAX	
o1	P1	13		
o2	P1	15		
o3	P1	17		
o4	P1	19		
o5	P1	21		
o6	P1	23		
o7	P1	25		
o8	P1	27		
o9	P1	29		
o10	P1	24		
o11	P1	26		
o12	M6	7 & 8	external	Collector / Emitter of 30 V - 60 mA optoinsulator
o16	P1	31	VA	ENB X (PNP output - 60 mA)
o17	P1	33		ENB Y (PNP output - 60 mA)
o18	P1	35		ENB Z (PNP output - 60 mA)
o19	P1	37	VAX	ENB W
o20	P2	18	internal	5V TTL
o21	P2	17		5V TTL
o22	P2	20		5V TTL
o23	P2	19		5V TTL
o24	P2	4		5V TTL
o25	P2	8		5V TTL
o26	P2	12		5V TTL
o27	P2	16		5V TTL
o32	P1	43	VAX	DIRO X
o33	P1	45		DIRO Y
o34	P1	47		DIRO Z
o40	P1	63	VA	24V PNP - 60 mA
o41	-	-	-	Buzzer management
o42	-	-	-	Led DL26
o48 *	P2	13	internal	Configurabile come i48 *
o49 *	P2	15		Configurabile come i49 *
o52 *	P2	32		Configurabile come i52 *
o53 *	P2	34		Configurabile come i53 *

\* 3,3V TTL I/O configurable together with Hardware parameter " I/O direction 48...53" (0 for inputs, 1 for outputs). With INT-185 interface these I/Os cannot be used as outputs but only like inputs i48, i49 and i52.

Tex Computer Srl  
Sede Legale e Amm.va  
47841 Cattolica (RN)  
Via Mercadante, 35 Italy  
Tel. +39 0541 832 511  
Fax. +39 0541 832 519  
commerciale@texcomputer.com

Tex Computer srl  
Ufficio Olgiate Olona  
21057 Olgiate Olona (VA)  
Corso Sempione, 96 Italy  
Tel +39 0331 643353  
Fax +39 0331 643766  
areanord@texcomputer.com

Tex Computer srl  
Ufficio Tecnico  
48018 FAENZA (RA)  
C.so Mazzini, 116 Italy  
Tel +39 0546 25967  
Fax +39 0546 28094  
ufficiotecnico@texcomputer.com

REA n. 208216  
Cap.Soc. 99.000,00 iv  
Part. IVA 01661960409  
Reg. Imp. di Rimini  
n. 01661960409  
[www.texcomputer.com](http://www.texcomputer.com)



## POWER J Data Sheet ENG

Page 16 of 27

Rel. 1.0.4 - January 11th, 2016

### ANALOG INPUTS (consecutive numbering)

input	connector	pin	full scale	notes
5	P2	24	0-10V	0-20 mA on request
6		23		
7		26		
8		25		
10	M5	2	0-5V	
11		3		
12		4		
13	M4	3	0-20 mA	
24	P2	27	0-5V	<b>Warning!</b> these inputs are not buffered and can be used only locally because they have no protection
25		29		
27	P1	60		
32	M4	1	+/- 10V	

### ANALOG OUTPUTS (consecutive numbering)

output	connector	pin	full scale	notes
5	P1	2	+/- 10V	from PWM with 12-14 bits resolution
6		4		
7		6		
8		8		

Tex Computer Srl  
Sede Legale e Amm.va  
47841 Cattolica (RN)  
Via Mercadante, 35 Italy  
Tel. +39 0541 832 511  
Fax. +39 0541 832 519  
commerciale@texcomputer.com

Tex Computer srl  
Ufficio Olgiate Olona  
21057 Olgiate Olona (VA)  
Corso Sempione, 96 Italy  
Tel +39 0331 643353  
Fax +39 0331 643766  
areanord@texcomputer.com

Tex Computer srl  
Ufficio Tecnico  
48018 FAENZA (RA)  
C.so Mazzini, 116 Italy  
Tel +39 0546 25967  
Fax +39 0546 28094  
ufficiotecnico@texcomputer.com

REA n. 208216  
Cap.Soc. 99.000,00 iv  
Part. IVA 01661960409  
Reg. Imp. di Rimini  
n. 01661960409  
[www.texcomputer.com](http://www.texcomputer.com)



# POWER J Data Sheet ENG

Page 17 of 27

Rel. 1.0.4 - January 11th, 2016

## CONNECTION EXAMPLES

This section is an extract of the information provided in the "Electrical Connections" section of the manual supplied with the controller, to which you must always refer for the wiring of the system according to the constructor's technical recommendations.

### Power supply and ground connection

Pin	Connector M1
1	24 VA +24 Vdc +/- 10%
2	GND A 0Vdc
3	GND A 0Vdc
4	VAX (jumper JP1 closed)

FT1

### Digital input and output connection

Pin	Connector P1
11	User output o0
30	GND A I/O power supply ground
31	ENBX X driver enable (60 mA)
32	VAX I/O +24 power supply
33	User output o17 (opto 60 mA)
40	FCZEROX X axis zero limit stop
41	FCEMG emergency stop
52	User in i16
53	User in i7
54	User in i20
55	GND A I/O power supply ground
56	GND A I/O power supply ground
57	
58	
59	
60	
61	GND A I/O power supply ground
62	VAX I/O +24 power supply
63	User output o40 (opto 60 mA)
64	VAX I/O +24 power supply

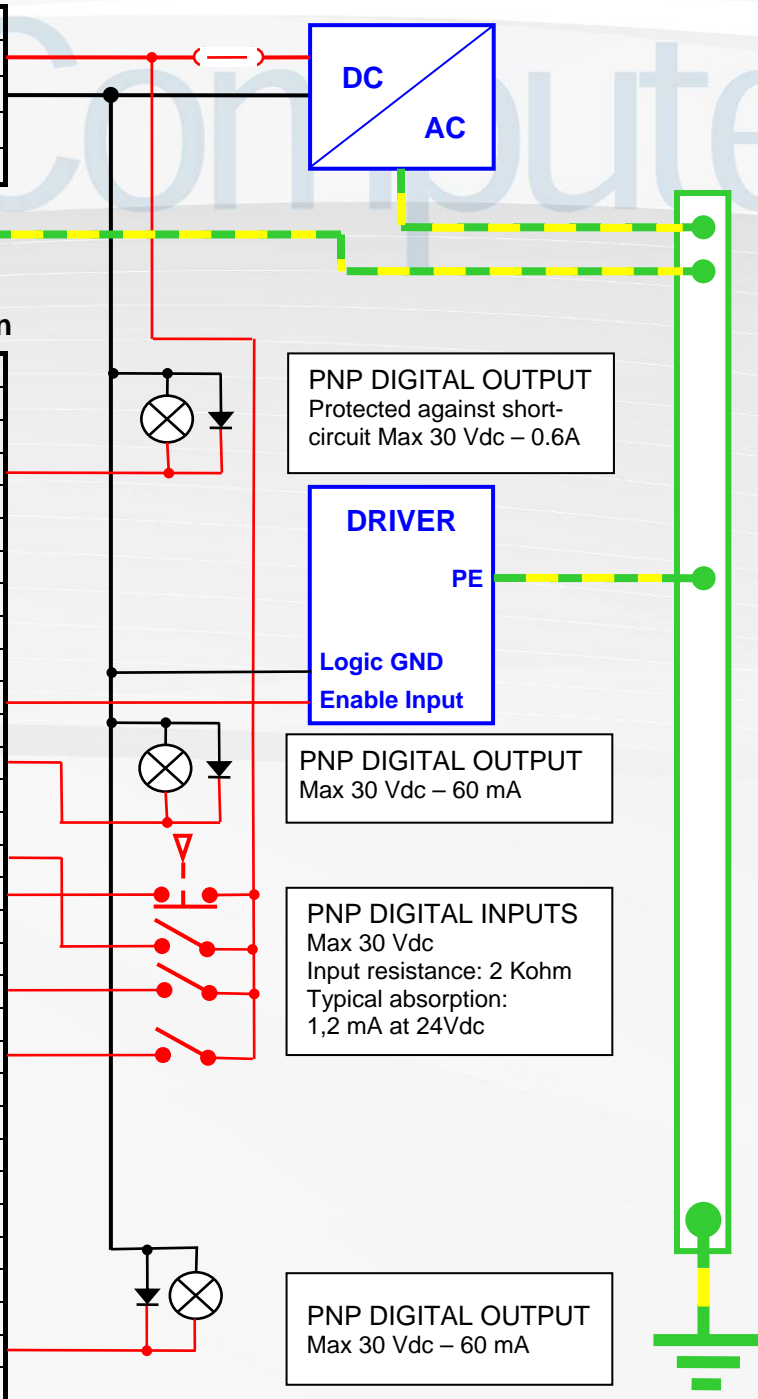

Tex Computer Srl  
Sede Legale e Amm.va  
47841 Cattolica (RN)  
Via Mercadante, 35 Italy  
Tel. +39 0541 832 511  
Fax. +39 0541 832 519  
commerciale@texcomputer.com

Tex Computer srl  
Ufficio Olgiate Olona  
21057 Olgiate Olona (VA)  
Corso Sempione, 96 Italy  
Tel +39 0331 643353  
Fax +39 0331 643766  
areanord@texcomputer.com

Tex Computer srl  
Ufficio Tecnico  
48018 FAENZA (RA)  
C.so Mazzini, 116 Italy  
Tel +39 0546 25967  
Fax +39 0546 28094  
ufficiotecnico@texcomputer.com

REA n. 208216  
Cap.Soc. 99.000,00 iv  
Part. IVA 01661960409  
Reg. Imp. di Rimini  
n. 01661960409  
[www.texcomputer.com](http://www.texcomputer.com)



# POWER J Data Sheet ENG

Page 18 of 27

Rel. 1.0.4 - January 11th, 2016

## Analog input connection

Pin	Connector M5
1	Analog GND
2	ADC (10) Analog input
3	ADC (11) Analog input
4	ADC (12) Analog input
5	Analog GND
6	+ 5V for potentiometer power supply

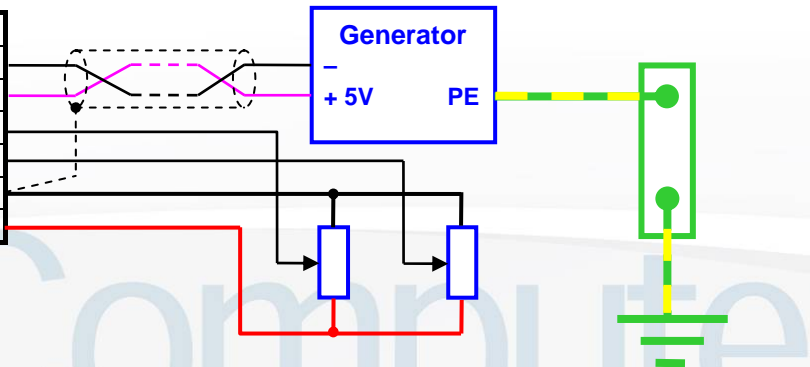

## Drive reference connection

Pin	Connector P1
1	GNDANAL X X axis analog ground
2	VREF X X reference signal, +/- 10V
9	GND logic ground

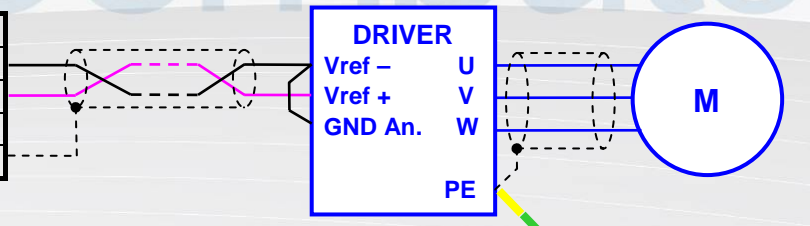

## 5V Line Driver Encoder connection

Pin	Connector M2
1	CLK A channel A straight enc. # 1
2	CLK/A channel A negated enc. # 1
3	CLK B channel B straight enc. # 1
4	CLK/B channel B negated enc. # 1
5	NOTCH /0 ch. 0 negated enc. # 1
6	NOTCH 0 ch. 0 straight enc. # 1
7	GND logic ground
8	VDC +5Vdc power supply

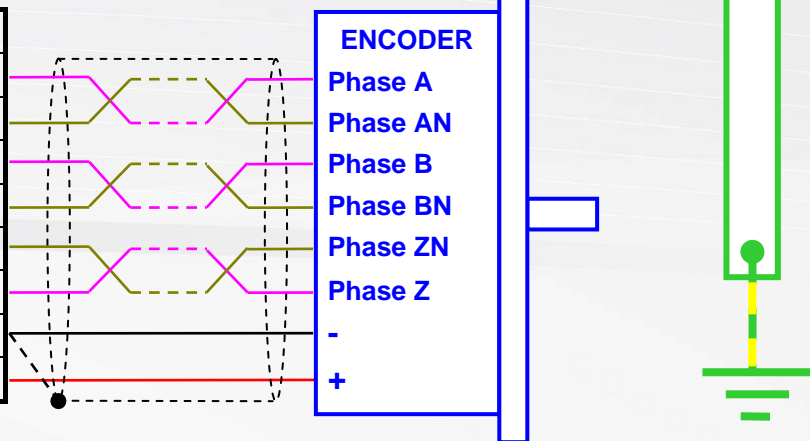

## Encoder connection to 5 V Push Pull terminal board M8 (optional)

Pin	Connector M8 (encoder # 4)
1	CLK A channel A straight
2	CLK/A channel A negated
3	CLK B channel B straight
4	CLK/B channel B negated
5	NOTCH /0 channel 0 negated
6	NOTCH 0 channel 0 straight
7	GDN logic ground
8	+ 5V for encoder power supply

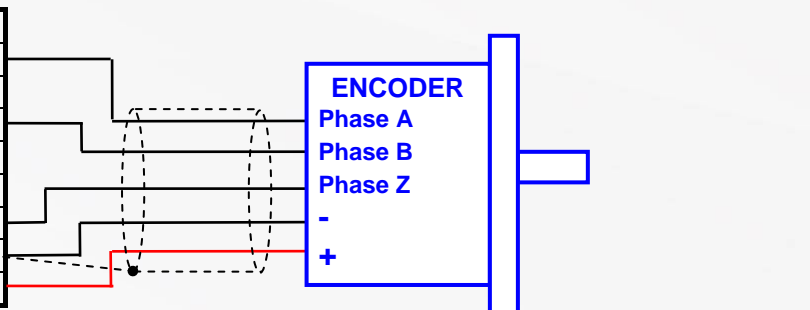

Tex Computer Srl  
Sede Legale e Amm.va  
47841 Cattolica (RN)  
Via Mercadante, 35 Italy  
Tel. +39 0541 832 511  
Fax. +39 0541 832 519  
commerciale@texcomputer.com

Tex Computer srl  
Ufficio Olgiate Olona  
21057 Olgiate Olona (VA)  
Corso Sempione, 96 Italy  
Tel +39 0331 643353  
Fax +39 0331 643766  
areanord@texcomputer.com

Tex Computer srl  
Ufficio Tecnico  
48018 FAENZA (RA)  
C.so Mazzini, 116 Italy  
Tel +39 0546 25967  
Fax +39 0546 28094  
ufficiotecnico@texcomputer.com

REA n. 208216  
Cap.Soc. 99.000,00 iv  
Part. IVA 01661960409  
Reg. Imp. di Rimini  
n. 01661960409  
[www.texcomputer.com](http://www.texcomputer.com)



# POWER J Data Sheet ENG

Page 19 of 27

Rel. 1.0.4 - January 11th, 2016

## Connection of RS232 serial interface Com. 1

Pin	Connector P6
1	GDN logic ground
2	Com. 1 RX
3	Com. 1 TX
4	
5	GDN logic ground
6	
7	Com. 2 TX
8	Com. 2 RX
9	VDC +5Vdc

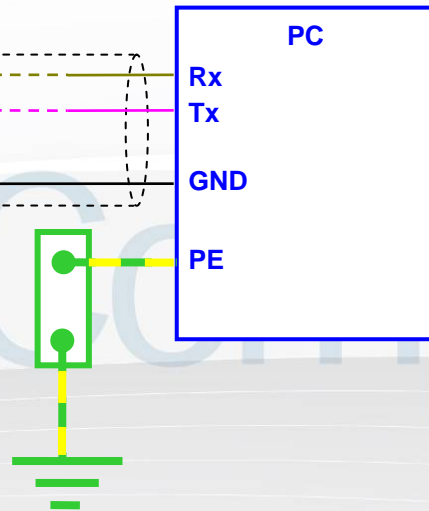

## Connection of RS485 serial interface Com. 1 (optional)

Pin	Connector P6
1	GDN logic ground
2	RTX + Com. 1
3	RTX - Com. 1
4	
5	GDN logic ground
6	
7	Com. 2 TX
8	Com. 2 RX
9	VDC +5Vdc

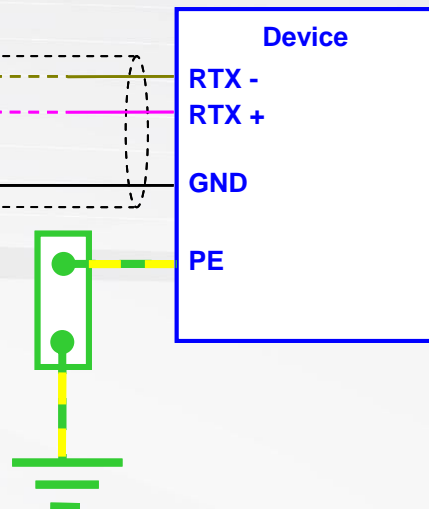

JP3 inserts the line start and end termination resistance of the RS485 (not connected by default).

Tex Computer Srl  
Sede Legale e Amm.va  
47841 Cattolica (RN)  
Via Mercadante, 35 Italy  
Tel. +39 0541 832 511  
Fax. +39 0541 832 519  
commerciale@texcomputer.com

Tex Computer srl  
Ufficio Olgiate Olona  
21057 Olgiate Olona (VA)  
Corso Sempione, 96 Italy  
Tel +39 0331 643353  
Fax +39 0331 643766  
areanord@texcomputer.com

Tex Computer srl  
Ufficio Tecnico  
48018 FAENZA (RA)  
C.so Mazzini, 116 Italy  
Tel +39 0546 25967  
Fax +39 0546 28094  
ufficiotecnico@texcomputer.com

REA n. 208216  
Cap.Soc. 99.000,00 iv  
Part. IVA 01661960409  
Reg. Imp. di Rimini  
n. 01661960409  
[www.texcomputer.com](http://www.texcomputer.com)



## POWER J Data Sheet ENG

Page 20 of 27

Rel. 1.0.4 - January 11th, 2016

### CANopen interface connection

The Power J is able to control up to 2 CAN ports using both the CiA 301 general communication protocol and the specific profiles CiA 401 (I/O devices), CiA 402 (drives) and CiA 406 (encoder).

**Be careful not to use in the same network devices CiA 401 and CiA 402 because it could result in a malfunction.**

The CAN network must be done with twisted screened cables and the furthest ends of CAN H and CAN L signals must be charged through a 120 ohm termination resistance.

In the Power J, the termination resistance is already connected by default and it can be disconnected removing jumper JP3, but you have to install the termination resistance at the other end of the network.

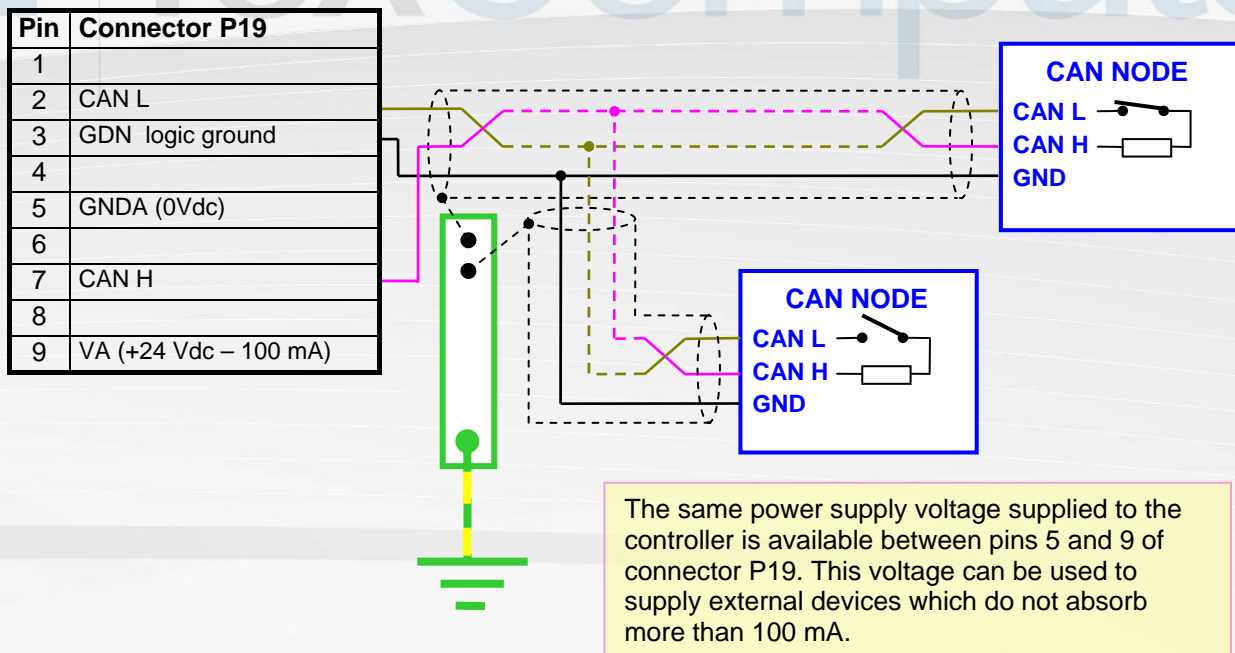

Tex Computer Srl  
Sede Legale e Amm.va  
47841 Cattolica (RN)  
Via Mercadante, 35 Italy  
Tel. +39 0541 832 511  
Fax. +39 0541 832 519  
commerciale@texcomputer.com

Tex Computer srl  
Ufficio Olgiate Olona  
21057 Olgiate Olona (VA)  
Corso Sempione, 96 Italy  
Tel +39 0331 643353  
Fax +39 0331 643766  
areanord@texcomputer.com

Tex Computer srl  
Ufficio Tecnico  
48018 FAENZA (RA)  
C.so Mazzini, 116 Italy  
Tel +39 0546 25967  
Fax +39 0546 28094  
ufficiotecnico@texcomputer.com

REA n. 208216  
Cap.Soc. 99.000,00 iv  
Part. IVA 01661960409  
Reg. Imp. di Rimini  
n. 01661960409  
[www.texcomputer.com](http://www.texcomputer.com)



**Basic functions of the touch screen**

On the controllers equipped with touch screen, a number of basic functions can be accessed immediately without having to enable and calibrate the screen.

1. If at start up the system detects a pressure at the top right-hand corner of the screen, it accesses **Boot menu:**

**BOOT FUNCTIONS**

- F1 = change card parameter
- F2 = touch screen calibration
- F3 = full ram clear
- F4 = reset
- F5 = load file
- F6 = clear screen
- F7 = save current firmware
- F8 = export card parameter

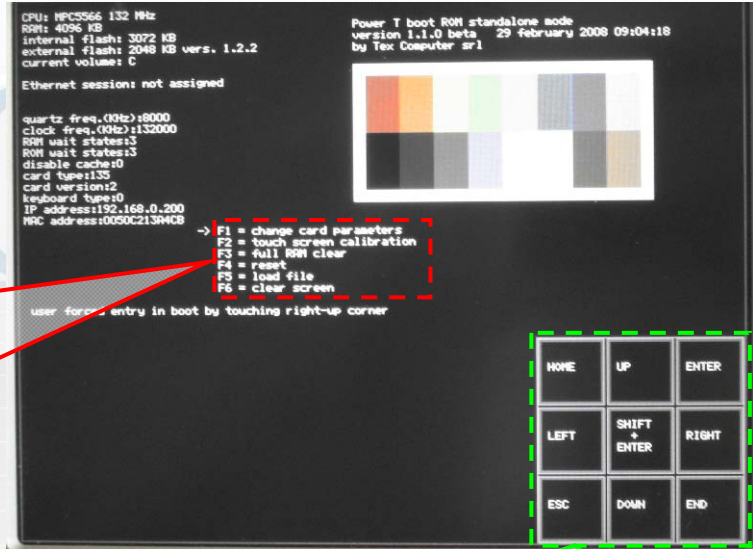

**Touch keys to browse boot functions**

**WARNING: the Boot menu manages only USB memories and no other peripherals, such as the keypad and the mouse, which may be connected to the same USB port through a hub.**

Once you are in Boot menu, we suggest you to calibrate the touch screen so that the touch function is still active when the system is switched on again, even after running functions F3 and F4 which partially or totally clear the RAM memory.

We recommend not to alter the card's basic configurations without contacting first the Tex Computer's technical staff.

2. If at start up the system detects a pressure at the top left-hand corner of the screen you enter the menu which allows the operator to disable some functions during the current start-up phase. The following check list will be displayed:

Touching the screen on each of the white boxes allows the user to check or un-check the functions to be disabled during the current start-up phase. Pressing ENTER you confirm the selections made, which affect the current start-up phase only and not the following ones

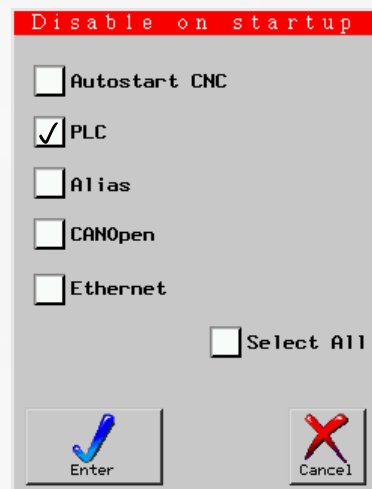

**For further information about the functions of the touch screen, refer to the manual with the same name.**

**Recalling Boot and Card recovery Functions from I1**

The controller is equipped with a microswitch, called I1, located on one side of the motherboard; next to it there is also a red LED DL26. Pressing the microswitch I1 at power on you can access both the Boot menu and the Card recovery functions which allow you to upload from a removable storage device, a text file, called POWER.CRD, where there are listed the values of the main card configuration parameters, including the IP address of the controller; these features are particularly useful for Box version controllers.

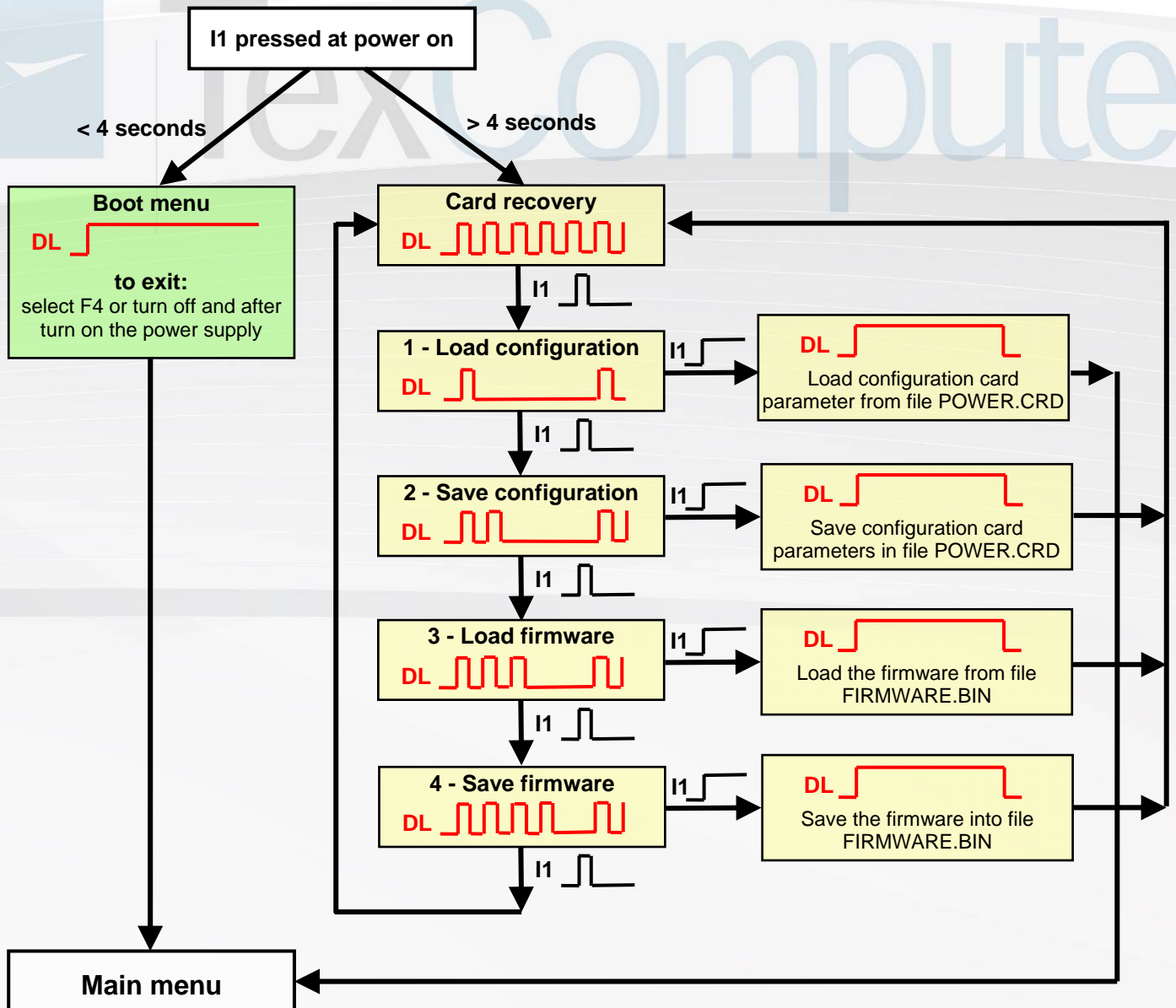

You can exit the Card recovery menu at any time by turning off and on the power supply of controller.

## POWER J Data Sheet ENG

Page 23 of 27

Rel. 1.0.4 - January 11th, 2016

### Interchangeability with Power P

Power J is designed so it can be used also as an alternative to Power P in applications where analog inputs present on the connectors J1, J2, J11 and J12 are not used.

However, there are also the following differences:

- The size of the motherboard of the Power J are such that it can be hosted behind the 7 " display panel without buttons
- In Power J output o40, which is connected to Pin 63 of P1, it is PNP type
- In Power J there are also present internal inputs I54 (alarm signal on the digital input modules) and I55 (alarm signal on the digital outputs modules)

The following table shows the changes to be made to achieve interchangeability:

Description	Power P	Power J	Interchangeability
P1 - Pin 63	o40 NPN	o40 PNP	with electrical changes

### Interchangeability with Power R

The Power J can be used as an alternative to the Power R with the exclusion of applications in which the ADC (0) analog input of Power R (P2 connector) is used.

The Power J can replace the Power R without any changes to the application program simply by moving some wiring of P1 connector, as shown in the following comparison table:

Resource	Power R P1 Conn.	Power J P1 Conn.
i0	Pin 52	Pin 16
i1	Pin 54	Pin 18
i2	Pin 56	Pin 20
i3	Pin 58	Pin 22
o8	Pin 38	Pin 27
o9	Pin 57	Pin 29
o10	Pin 60	Pin 24
o11	Pin 59	Pin 26
o16	Pin 49	Pin 31
o17	Pin 51	Pin 33
o18	Pin 53	Pin 35
o19	Pin 59	Pin 37

Also the wiring diagrams of encoders must be modified because, in the Power J, they are no longer wired to the connector P1 because they must be connected each one to its own terminal board.

**Warning!** The connector P6, dedicated to the connection of the serial ports, is interchangeable only if the supply voltage outgoing from pin 9 it is not used; in fact in Power J it is connected to + 5V DC, while in Power R it is connected to VAX, which usually is + 24V DC. Failure to comply with this recommendation can cause irreversible damage to the controller.

Tex Computer Srl  
Sede Legale e Amm.va  
47841 Cattolica (RN)  
Via Mercadante, 35 Italy  
Tel. +39 0541 832 511  
Fax. +39 0541 832 519  
commerciale@texcomputer.com

Tex Computer srl  
Ufficio Olgiate Olona  
21057 Olgiate Olona (VA)  
Corso Sempione, 96 Italy  
Tel +39 0331 643353  
Fax +39 0331 643766  
areanord@texcomputer.com

Tex Computer srl  
Ufficio Tecnico  
48018 FAENZA (RA)  
C.so Mazzini, 116 Italy  
Tel +39 0546 25967  
Fax +39 0546 28094  
ufficiotecnico@texcomputer.com

REA n. 208216  
Cap.Soc. 99.000,00 iv  
Part. IVA 01661960409  
Reg. Imp. di Rimini  
n. 01661960409  
[www.texcomputer.com](http://www.texcomputer.com)



# POWER J Data Sheet ENG

Page 24 of 27

Rel. 1.0.4 - January 11th, 2016

## Power J 7" Compact dimensions

Dim. in mm

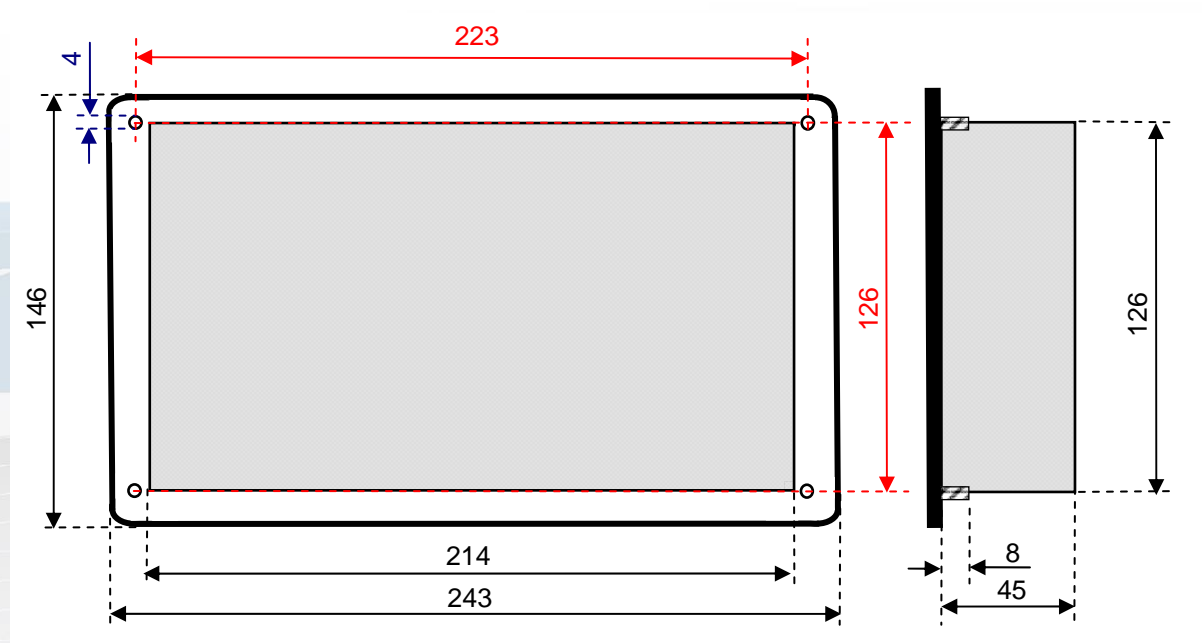

## Power J 7" Compact drilling template

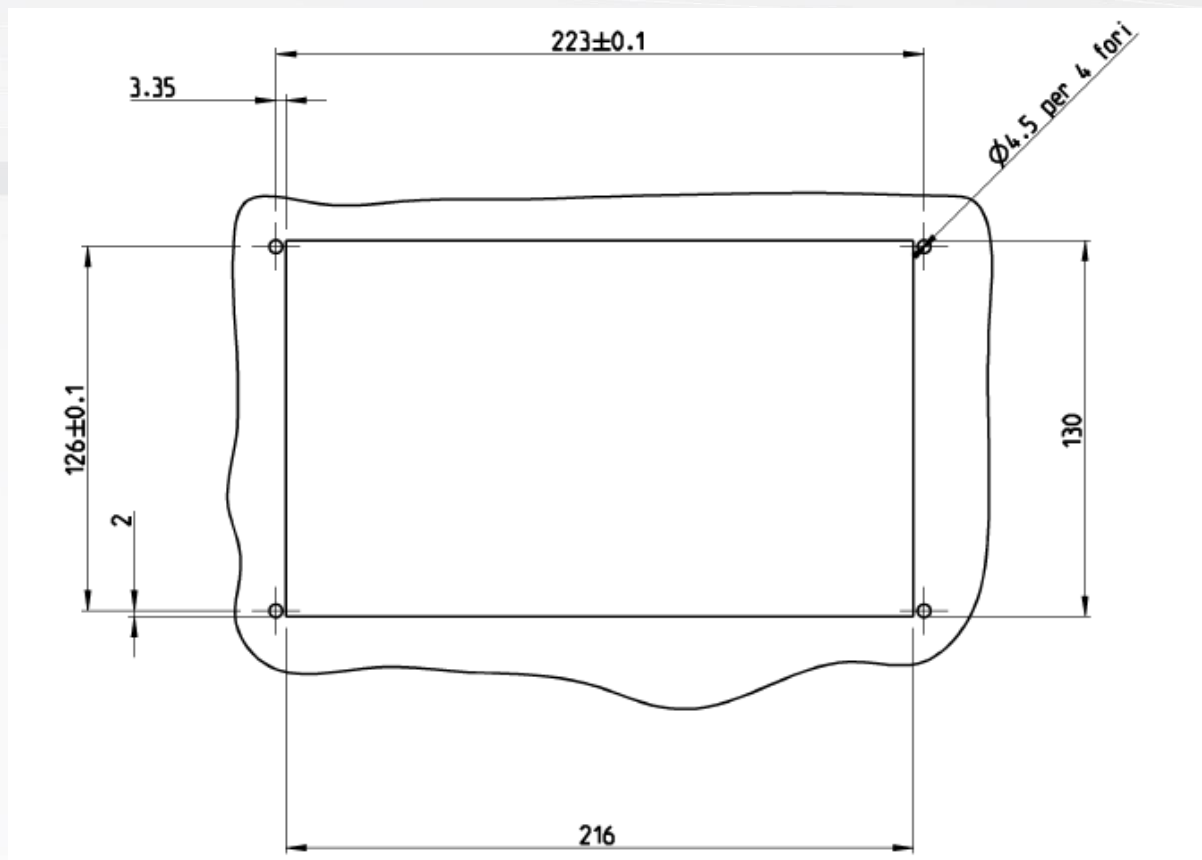

Tex Computer Srl  
Sede Legale e Amm.va  
47841 Cattolica (RN)  
Via Mercadante, 35 Italy  
Tel. +39 0541 832 511  
Fax. +39 0541 832 519  
commerciale@texcomputer.com

Tex Computer srl  
Ufficio Olgiate Olona  
21057 Olgiate Olona (VA)  
Corso Sempione, 96 Italy  
Tel +39 0331 643353  
Fax +39 0331 643766  
areanord@texcomputer.com

Tex Computer srl  
Ufficio Tecnico  
48018 FAENZA (RA)  
C.so Mazzini, 116 Italy  
Tel +39 0546 25967  
Fax +39 0546 28094  
ufficiotecnico@texcomputer.com

REA n. 208216  
Cap.Soc. 99.000,00 iv  
Part. IVA 01661960409  
Reg. Imp. di Rimini  
n. 01661960409  
[www.texcomputer.com](http://www.texcomputer.com)



# POWER J Data Sheet ENG

Page 25 of 27

Rel. 1.0.4 - January 11th, 2016

## Power J 10" Compact dimensions

Dim. in mm

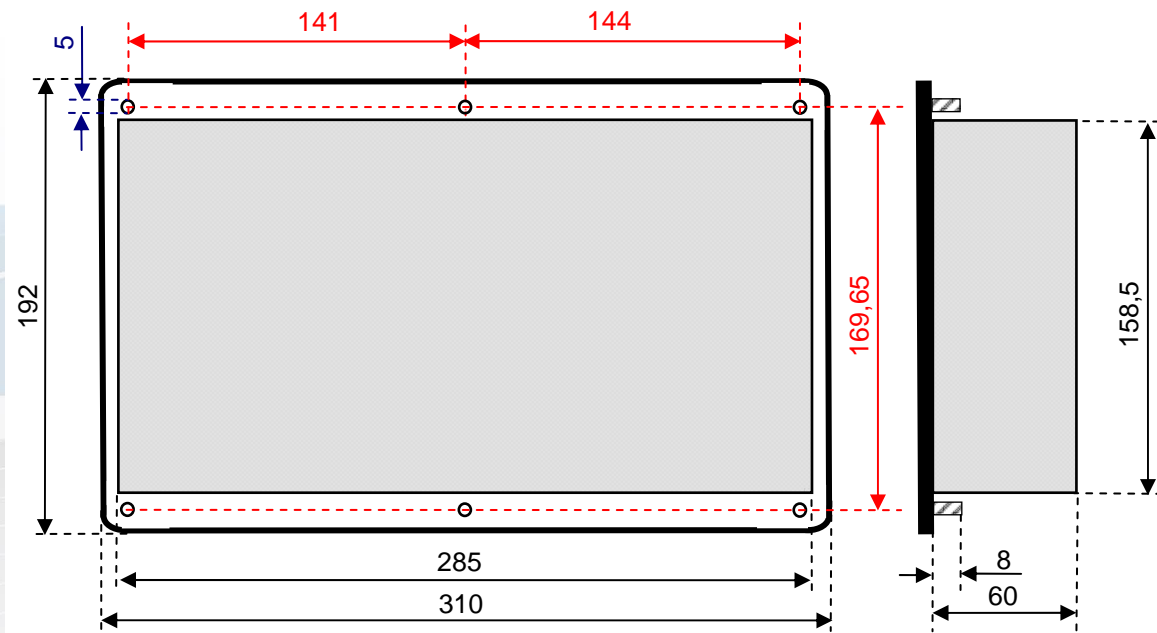

## Power J 10" Compact drilling template

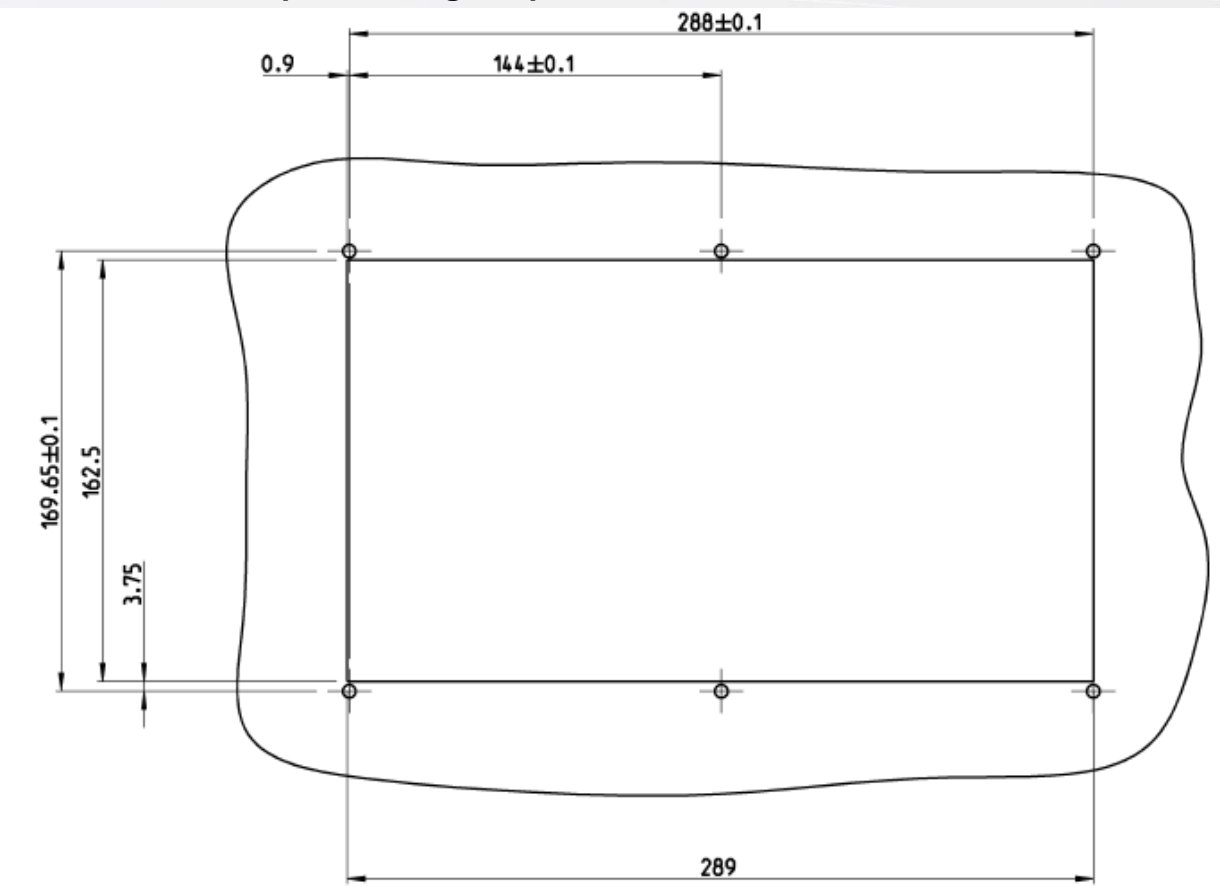

Tex Computer Srl  
Sede Legale e Amm.va  
47841 Cattolica (RN)  
Via Mercadante, 35 Italy  
Tel. +39 0541 832 511  
Fax. +39 0541 832 519  
commerciale@texcomputer.com

Tex Computer srl  
Ufficio Olgiate Olona  
21057 Olgiate Olona (VA)  
Corso Sempione, 96 Italy  
Tel +39 0331 643353  
Fax +39 0331 643766  
areanord@texcomputer.com

Tex Computer srl  
Ufficio Tecnico  
48018 FAENZA (RA)  
C.so Mazzini, 116 Italy  
Tel +39 0546 25967  
Fax +39 0546 28094  
ufficiotecnico@texcomputer.com

REA n. 208216  
Cap.Soc. 99.000,00 iv  
Part. IVA 01661960409  
Reg. Imp. di Rimini  
n. 01661960409  
[www.texcomputer.com](http://www.texcomputer.com)



## POWER J Data Sheet ENG

Page 26 of 27

Rel. 1.0.4 - January 11th, 2016

### Power J 10" - 56 keys dimensions

Dim. in mm

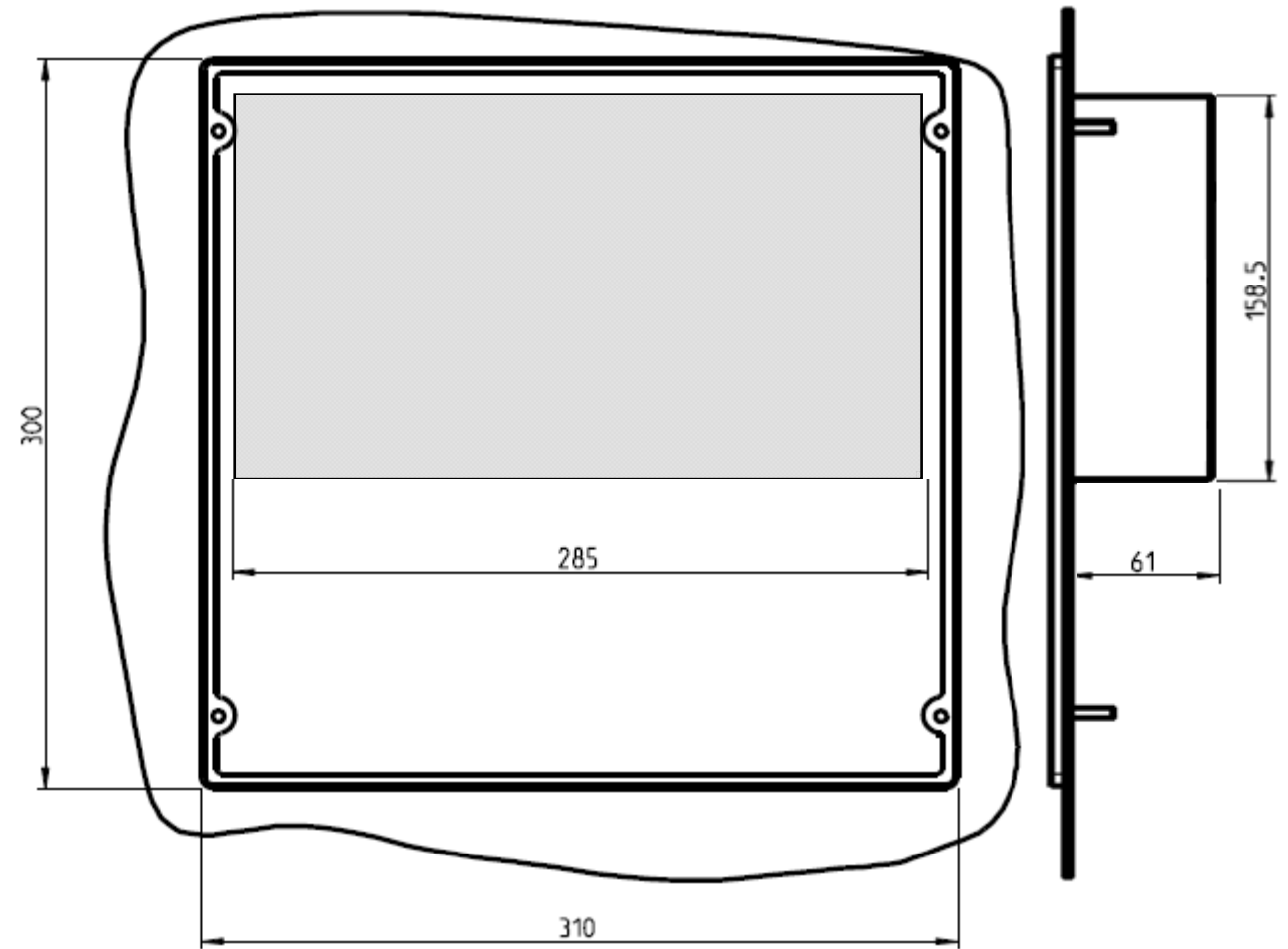

**Tex Computer Srl**  
Sede Legale e Amm.va  
47841 Cattolica (RN)  
Via Mercadante, 35 Italy  
Tel. +39 0541 832 511  
Fax. +39 0541 832 519  
commerciale@texcomputer.com

**Tex Computer srl**  
Ufficio Olgiate Olona  
21057 Olgiate Olona (VA)  
Corso Sempione, 96 Italy  
Tel +39 0331 643353  
Fax +39 0331 643766  
areanord@texcomputer.com

**Tex Computer srl**  
Ufficio Tecnico  
48018 FAENZA (RA)  
C.so Mazzini, 116 Italy  
Tel +39 0546 25967  
Fax +39 0546 28094  
ufficiotecnico@texcomputer.com

REA n. 208216  
Cap.Soc. 99.000,00 iv  
Part. IVA 01661960409  
Reg. Imp. di Rimini  
n. 01661960409  
[www.texcomputer.com](http://www.texcomputer.com)



# POWER J Data Sheet ENG

Page 27 of 27

Rel. 1.0.4 - January 11th, 2016

## Power J 10" - 56 keys drilling template

Dim. in mm

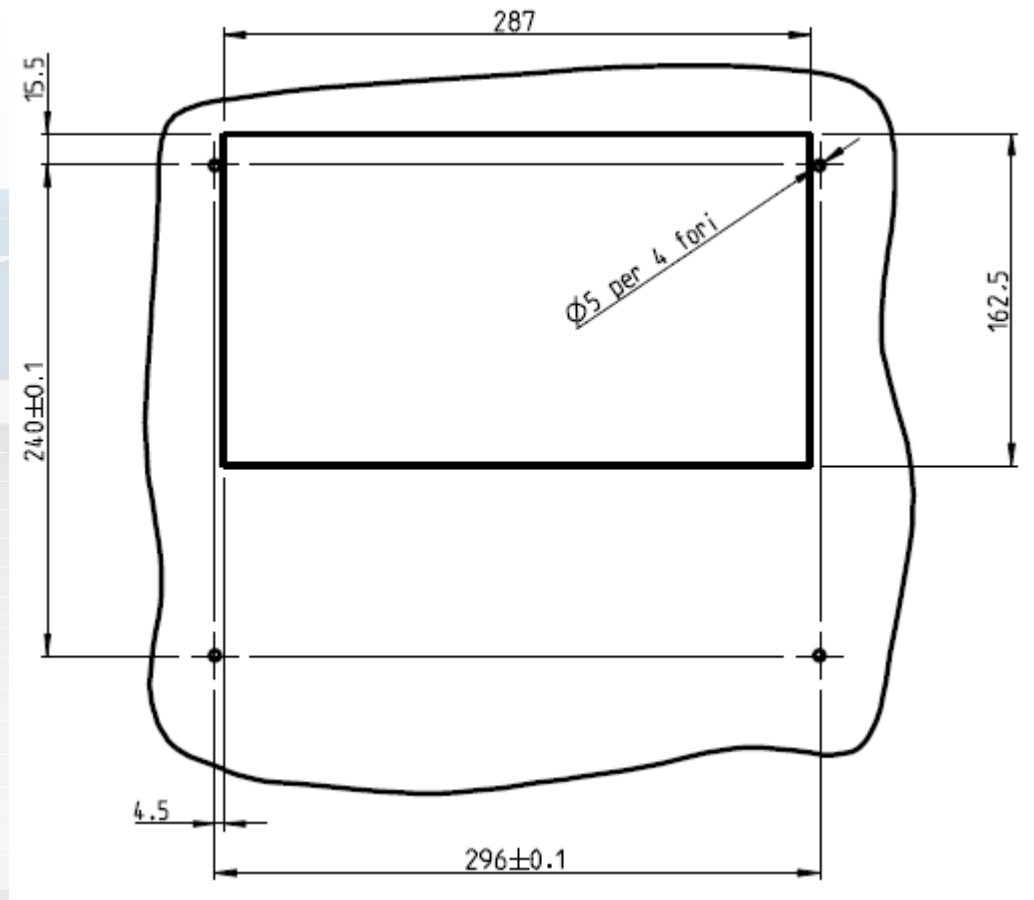

Data subject to modification without notice

Tex Computer Srl  
Sede Legale e Amm.va  
47841 Cattolica (RN)  
Via Mercadante, 35 Italy  
Tel. +39 0541 832 511  
Fax. +39 0541 832 519  
commerciale@texcomputer.com

Tex Computer srl  
Ufficio Olgiate Olona  
21057 Olgiate Olona (VA)  
Corso Sempione, 96 Italy  
Tel +39 0331 643353  
Fax +39 0331 643766  
areanord@texcomputer.com

Tex Computer srl  
Ufficio Tecnico  
48018 FAENZA (RA)  
C.so Mazzini, 116 Italy  
Tel +39 0546 25967  
Fax +39 0546 28094  
ufficiotecnico@texcomputer.com

REA n. 208216  
Cap.Soc. 99.000,00 iv  
Part. IVA 01661960409  
Reg. Imp. di Rimini  
n. 01661960409  
[www.texcomputer.com](http://www.texcomputer.com)

